



**SILENT**  
We're The Vibrator Guys.™

**FAX: 401-539-2584**

**\* = INFORMATION REQUIRED FOR PROPER VIBRATOR RECOMMENDATION**

COMPANY \_\_\_\_\_  
 CONTACT NAME \_\_\_\_\_  
 ADDRESS \_\_\_\_\_  
 \_\_\_\_\_  
 PHONE \_\_\_\_\_ FAX \_\_\_\_\_  
 EMAIL \_\_\_\_\_

**SCREEN**

Screen Design:  Side Walls? Wall Height (if applicable): \_\_\_\_\_  
 Multi Screens? Number of Screens: \_\_\_\_\_ Mesh Size: \_\_\_\_\_  
 Screen Width : \_\_\_\_\_ Screen Length: \_\_\_\_\_  
 Screen Weight: \_\_\_\_\_ Screen Angle Off Horizontal: \_\_\_\_\_  
 Isolation Between Screen & Other Equipment (stand, hopper, chute, etc.)?  Yes  No  
 Isolation is:  Rubber Mounts or Pads  Coil Springs  Air Mounts

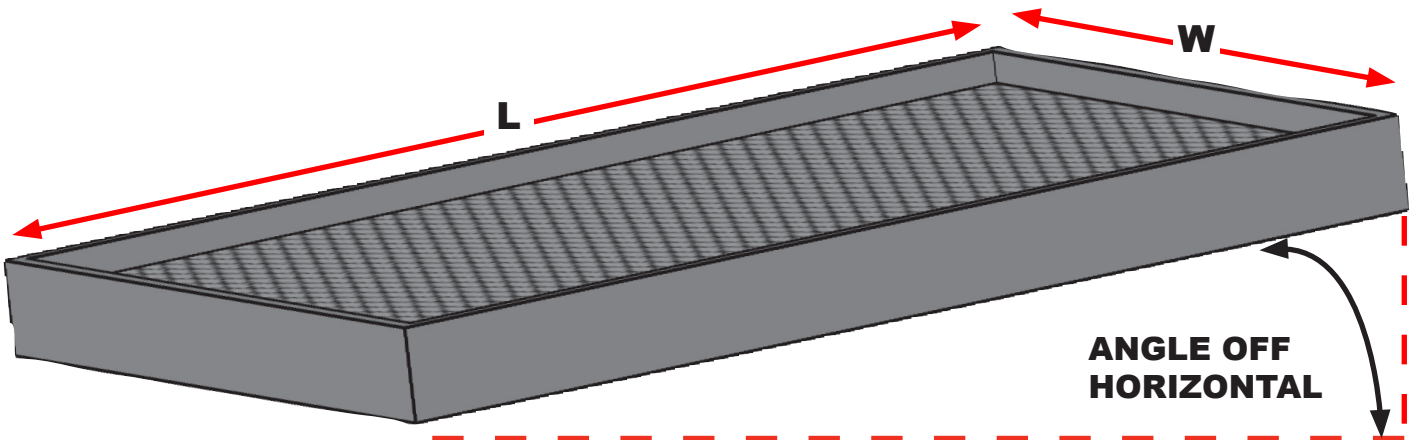

**\*\* ADDITIONAL INFORMATION REQUESTED \*\***

Engineering drawings & digital picture(s) of application via email to [vibrators@vibco.com](mailto:vibrators@vibco.com).  
 Or please include dimensions & notes regarding your application/problems on this form and fax it to **401-539-2584**.

**MATERIAL TO BE SCREENED/VIBRATED \***

Type (not brand name): \_\_\_\_\_  
 Moisture & Texture:  dry  damp  wet  granular  powder  
 Weight per cubic foot: \_\_\_\_\_ lbs  
 % of Material to Pass Through Screen: \_\_\_\_\_

**POWER AVAILABLE - preferred \***

AIR Volume \_\_\_\_\_ CFM at \_\_\_\_\_ PSI pressure at vibrators (not at compressor): \_\_\_\_\_  
 ELECTRIC Phase \_\_\_\_\_ Volts \_\_\_\_\_ Cycles \_\_\_\_\_ AC \_\_\_\_\_ DC \_\_\_\_\_  
 HYDRAULIC GPM \_\_\_\_\_ PSI \_\_\_\_\_