

Head Office
Vibco, Inc.
 75 Stilson Road
 Wyomomg, RI 02898
 TEL. 800-633-0032
 FAX. 401-539-2584

We're The **SILENT**
 Vibrator Guys.®

Canadian Branch
Vibco Canada
 2215 Dunwin Drive
 Mississauga, Ontario L5L1X1
 TEL. 905-828-4191
 FAX. 905-828-5015



WWW.VIBCO.COM

Operators Manual

VR-18 High Compaction Reversible Dirt Plate Compactor
VRA-18 High Compaction Reversible Asphalt Plate Compactor

Engine Specs

Honda GX-120
 Four cycle, gasoline, air cooled
 Overhead valve, slant cylinder
 Dual element heavy-duty air cleaner
 4.0 Horsepower / 3 Kilowatts
 3250 RPM
 Rewind starter
 Low oil alert system
 Transistorized magneto ignition

Tamper Specifications

| <u>Specification</u> | <u>English</u> | <u>Metric</u> |
|-----------------------------|---------------------------|----------------------|
| Weight | 170 lbs | 77 kg |
| Centrifugal Force | 3000 lbs | 13.3 kN |
| Specific Centrifugal Force | 10.9 psi | 75 kPa |
| Vibration Frequency | 5200 VPM | 87 hz |
| Compaction Depth | 12" | 30 cm |
| Contact Dimensions | 17.5" width x 15.75" long | 44 cm x 40 cm |
| Overall Width | 18" | 46 cm |
| Overall Length | 22" | 56 cm |
| Water Tank Capacity | 5 Quarts | 4.7 Liters |

Introduction

Vibco plate type compactors are used for compacting loose layers of soil or asphalt into load bearing surfaces. The vibration aligns the particles in the material being compacted in order to achieve maximum density, thus eliminating hollow spaces or cavities. They are successfully used for sandy, granular and partially cohesive materials, as well as for asphalt finishing. The main components of the compactors are; the base plate, vibratory element, engine plate, steering handle and a water tank on asphalt models. The vibrational force and forward motion of these machines is induced by rotation of an eccentrically weighted shaft. The water tank on asphalt models wets the plate and pavement surfaces appropriately to avoid the adhesion, which can occur with the asphalt surface.

Serial Number Location

Engine

When ordering replacement parts from the engine distributor, state the model, specification and serial number. Model and spec. numbers for both engines are located on the flywheel cover. Honda serial numbers are found on the front of the crankcase housing and the Robin serial numbers are located on the base of the engine.

Compactor

The Vibco model and serial numbers are mounted on the front of the engine plate. Furnish both numbers when corresponding with your authorized dealer.

Maintenance

Keep your machine clean!

Every 10 hours or daily

1. Periodically check bolts and nuts for tightness, especially in the period following initial operation.
2. Check engine oil daily.
3. Clear air filter periodically
4. Check and tighten element clamp screws with a torque wrench for 38-40 ft-lbs.

Every 50 hours or weekly

1. Check belt tension.
2. Change engine oil.
3. Check and tighten all nuts and bolts.
4. If water flow through the sprinkler pipe on asphalt units fails, clear pipe using carburetor cleaner.
5. Check vibrator element seal for leaks.

Vibco, Inc. reserves the right to change or improve any parts of specification without notice, and without incurring any obligation relating to such change.

Operating Notes

- Before starting the machine, **READ** the engine operating manual **CAREFULLY**, and check the engine oil.
- The vibratory element is filled with 2 oz. of **SAE 90 EP** gear lubricant, and is sealed at the factory. Do not overfill the element if servicing, this can damage the unit extensively.
- Unlock the handle by removing the handle lock pin located under the recoil starter. Now the machine is ready to start.
- Reverse: When reversing the travel,
 - A. Remove the handle lock pin and swing the handle over the engine and walk behind the machine.
 - B. If walking backwards with the machine, place the lock pin in the second position so you can guide the machine and lift handle to prevent baseplate from digging into loose soil.
- After warm up, move the control lever to the full throttle position. The motor should run at 3250 RPM maximum. The clutch will automatically engage at about 1600 RPM, and vibration will begin. The tamper will begin to move itself.
- To change the direction of travel, move the lever arm in the same direction of current motion.
- Let compactor move on its own power, and guide it by the handle. For uphill compaction, you may flip the handle over and help pull the compactor slightly. When traveling sideways on a sloped surface it may be necessary to steer the compactor toward the uphill direction to prevent slipping. Be sure the machine is in the forward direction on the uphill.
- Do not add fuel while engine is running. Stop the engine and, if possible, allow a cooling period to prevent spilled fuel from igniting on contact with hot engine parts.
- Before making any adjustments, disconnect the spark plug cable to prevent unintentional starting.
- Make sure the belt guard is firmly bolted in place before operation.
- To stop the compactor, move the throttle back to the idle position. To shut down the engine, turn the ignition kill switch to off and hold until the engine has completely stopped.
- **REMEMBER!** A careful operator is always the best insurance against accidents.

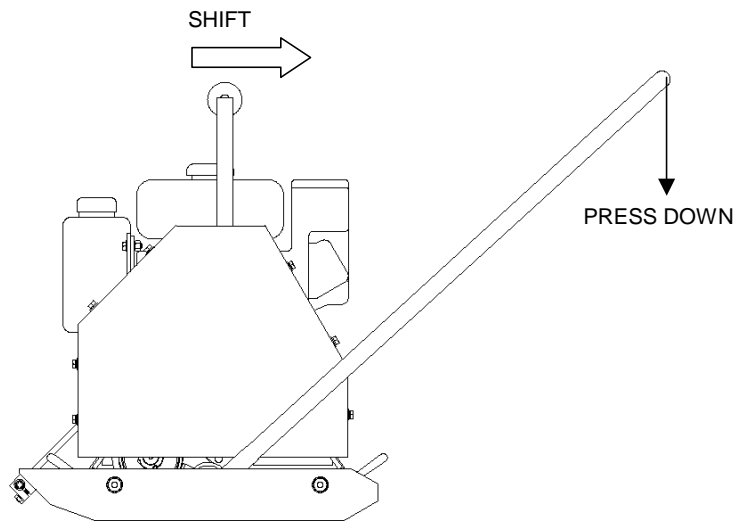

FIGURE 1

← FORWARD TRAVEL

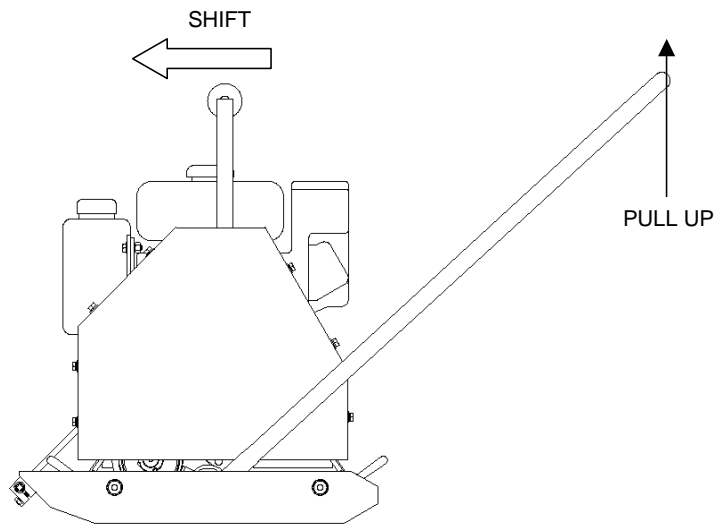

FIGURE 2

→ REVERSE TRAVEL

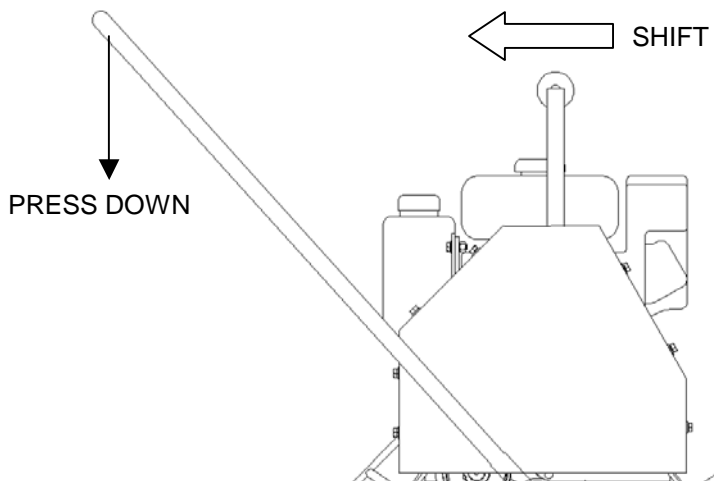

FIGURE 3

→ REVERSE TRAVEL

Forward Figure 1

- A. Move the shift handle towards you.
- B. By pressing the handle down while operating the unit will have a more steady travel forward and accomplish a better compaction. Doing this will also help the unit over lumps, stones and inclines.

Reverse Figure 2

- A. Move the shift handle away from you.
- B. When walking backwards behind the unit (ex. while in a ditch) insert the handle pin to lock the handle in one position. If the material to be compacted is very soft, the plate may have a tendency to dig in. To avoid this, simply pull up on the handle. This will allow the unit to travel very easily.

Reverse Figure 3

- A. This unit has the feature of a swinging handle, which allows the operator to swing the handle over the engine to the other side so he or she may walk behind the unit when traveling in reverse.

Lifting

- A. Use the carrying handles welded onto the engine plate.
- B. You may also lift the unit by the handle by first inserting the handle pin to lock the handle in the vertical position.