

VIBCO

VIBRATORS

VIBRA-BEAM

Countertop System™

Models: VB-250, VB-320, VB-450

- **Totally portable, light-weight & small**
- **Mounts to any standard sawhorse**
- **Produce a tight, dense, void-free finish ANYWHERE**
- **Low cost alternative to a vibrating table**

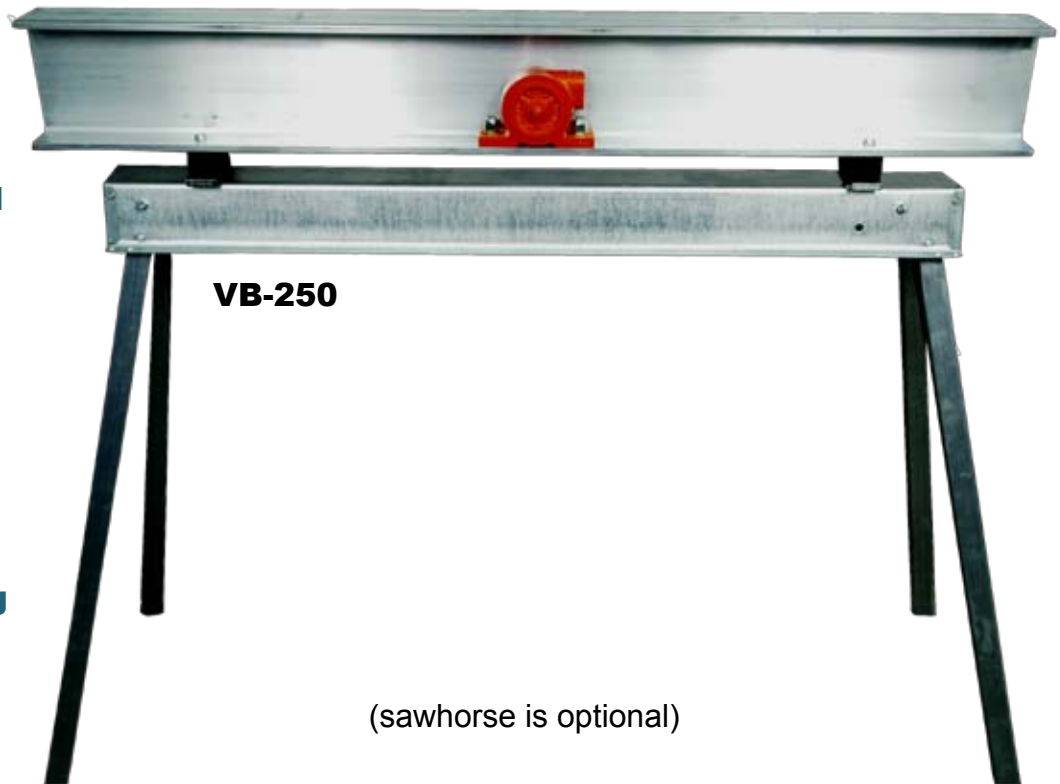

VIBRA-BEAM COUNTERTOP SYSTEM™

VIBCO's Vibra-Beam Countertop System™ is a state-of-the-art, patent pending countertop vibration system. This light weight vibration system can be attached to any standard saw horse allowing you to create a low cost, high quality vibratory table. A table capable of producing the tightest, most dense and void-free finish for any concrete product.

The Vibra-Beam Countertop System™ is available in either 115/230 Volt AC-DC power or pneumatic, offering a versatile, low-cost, portable solution to concrete finishing. This system is easily adaptable to fit any countertop casting by simply adding an additional Vibra-Beams.

VIBCO recommends installing a minimum of two Vibra-Beam units for sections 0-8 feet in length for maximum vibration transfer.

100% made in the USA, the design for the Vibra-Beam Countertop System™ draws from some of the best qualities of VIBCO's time-tested, industry standards. Scaled down to be easily portable for smaller applications, the Vibra-Beam™ still provides the quality-engineered product for which VIBCO is known.

You asked for it and **VIBCO** built it! **VIBRA-BEAM Countertop System™** is the most versatile unit with applications in precast, concrete countertops, patio stones, ornamental concrete, and much, much more.

800.633.0032 • www.VIBCO.com

VIBCO VIBRA-BEAM COUNTERTOP SYSTEM™

DIMENSIONS

UNITS	OVERALL SYSTEM DIMENSIONS					MOUNTING HOLES		BEAM DIMENSIONS	
	LENGTH			WIDTH	HEIGHT	HOLE SIZE	HOLE SPREAD	WIDTH	HEIGHT
	VAR 1	VAR 2**	VAR 3						
inch	36	42	46	4	7 3/4	3/8**	32	4	6
mm	915	1065	1170	100	200	10	815	100	150

++Standard length **BOLT SIZE

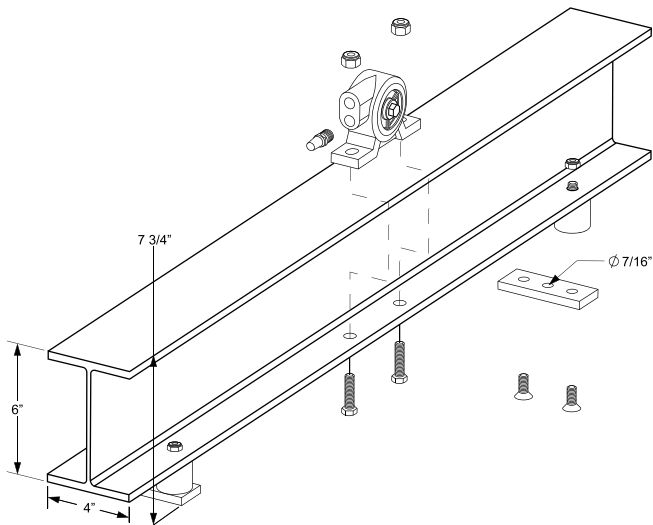

**Build Your Own
Custom Vibrating
Table with the
VIBRA-BEAM
Countertop System™**

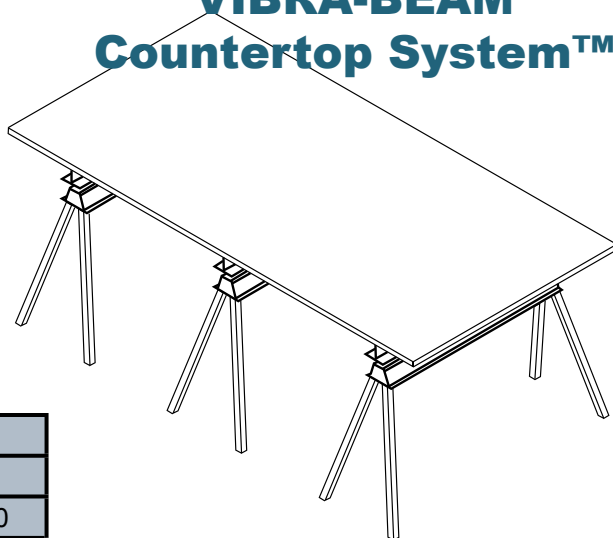

TECHNICAL DATA

PNEUMATIC VIBRATOR	80 PSI		FORCE		VOLTS	Ph.	DUTY
	VPM	CFM	lbs.	N			
V-250	11000	13	380	1700	115/230 AC - DC	1	INTERMITTENT
V-320	10000	17	650	2900			
ELECTRIC VIBRATOR	MAX SPEED	FORCE			VOLTS	Ph.	DUTY
		lbs.	N	AMPS			
US-450T	9000 VPM	450	2000	3/1.5	115/230 AC - DC	1	INTERMITTENT

N= Centrifugal force in Newtons

VIBCO VIBRATING TABLES:

NEED A CUSTOM TABLE FOR A SPECIAL APPLICATION?

CALL FOR A FREE VIBRATING TABLES CATALOG TODAY.



We're The Vibrator Guys™

World Headquarters:

75 Stilson Rd., P.O. Box 8
Wyoming, RI 02898

E-Mail: vibrators@VIBCO.com

Phone: (401) 539-2392

800-633-0032

FAX: (401) 539-2584

Canada:

2215 Dunwin Drive
Mississauga, Ont. L5L 1X1

Phone: (905) 828-4191

(800) 465-9709

FAX: (905) 828-5015

Southeast:

12001 North Dr. Martin
Luther King Dr.

Unit 2703

Saint Petersburg, FL 33716

Phone: (401) 864-5117

FAX: (401) 578-9509

**CONTACT
VIBCO
ABOUT A 10-DAY
FREE TRIAL**

Available for any VIBCO standard unit. With the help of our Application Engineers, we will get you the vibrator that will work best for you. Try it for 10-days at **NO RISK.**

REV103-10

800.633.0032 • www.VIBCO.com